

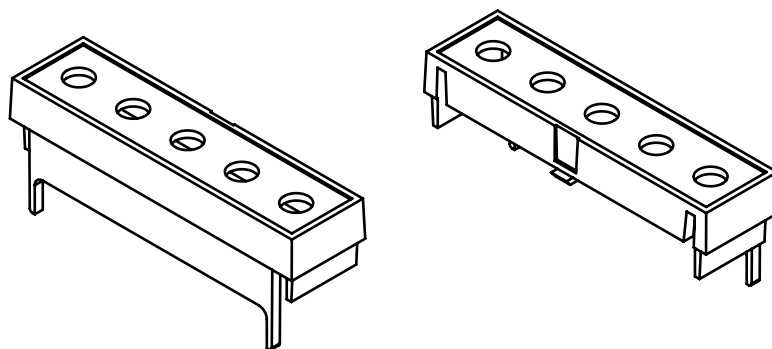



SECTION A-A

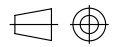

General information:

-  Workpiece zero point for mechanical processing
- Minimum recommended radius for machining = R1.0 mm

General Tolerance UNI EN 22768/1 Media (m)					Sheet:	
from 0.5 to 3 ± 0.1	from 3 to 6 ± 0.1	from 6 to 30 ± 0.2	from 30 to 120 ± 0.3	from 120 to 400 ± 0.5	1	
Scale: 1:1	Drawn:	Checked: R.N.	Date: 12/06/2023	Material: PC/ABS	Process: INJECTION	
Dimension in mm 		Derived from: --	Weight: 2.91 gr		Cod. Mold: ST.05CV000	
 italtronic enclosures for electronics italtronic.com			Description: COPRIMORSETTO PREFORATO PASSO 10,16 5 VIE 3MP10 TERMINAL COVER MODULBOX PRE-HOLED 3MP10 PITCH 10,16 5 POLES Drawing nr.: 2_250_03730			
					Rev.:	A4
					00	